

GRATING

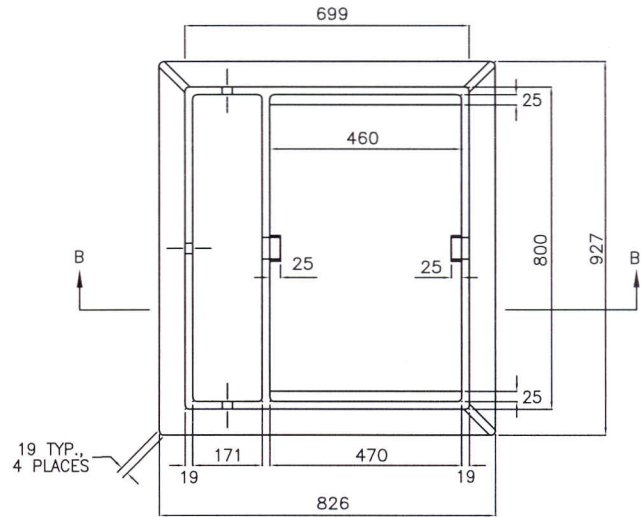

FRAME

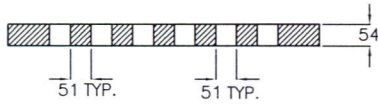

SECTION A-A

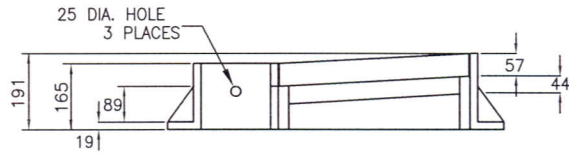

SECTION B-B

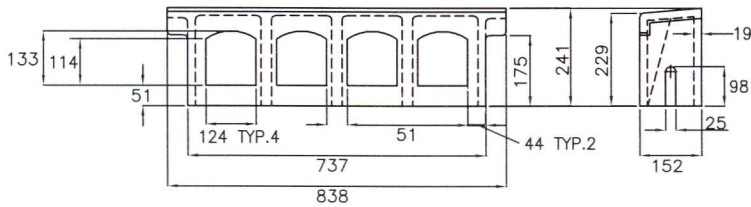

CURB

NOTES:

1. USE S400/S410 FRAME AND COVER FOR MANHOLES.
2. ALL DIMENSIONS ARE IN MILLIMETRES UNLESS OTHERWISE NOTED.

Scale : N.T.S.
 Drawn by : M.LABRECHE
 Checked by : W.DEVEAU
 Date of Plan : AUG2009
 File No. : S-2009-059

Philip Cohen
 Manager Highway Planning and Design

W. Deveau
 Director Highway Engineering Services

W. Deveau
 Executive Director Highway Engineering and Construction



Transportation and Infrastructure Renewal

No. REVISION

**S361 CATCH BASIN
 FRAME, GRATING & CURB**