

SECTION A-A
(WHEEL GUARD)

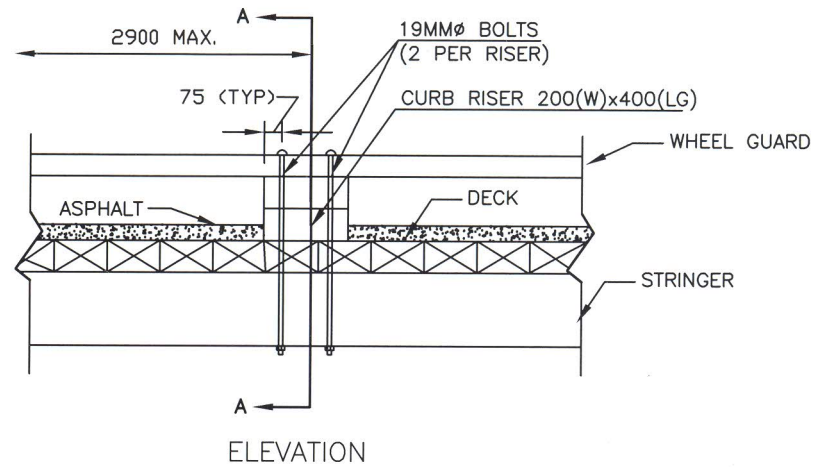

ELEVATION

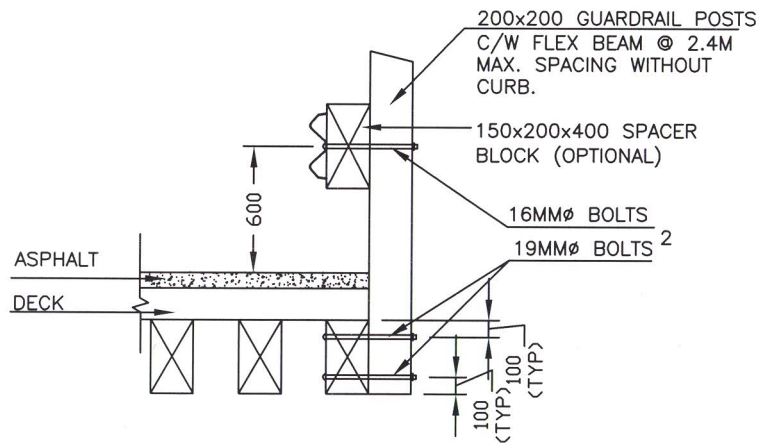

SECTION A-A
(GUARDRAIL)

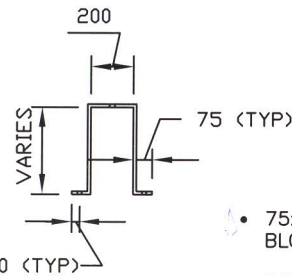

METAL STRAP

- 75x12.5 SIZED TO POST AND BLOCKING.
- CONNECTED TO STRINGER WITH 2-22MMØ LAG SCREWS, LENGTH SAME AS STRINGER WIDTH.
- SPIKE STRAP TO POST

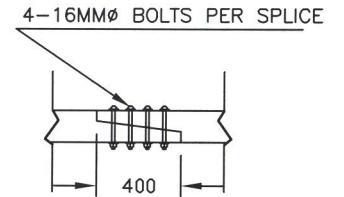

WHEEL GUARD SPLICE

- NOTES:
1. GALVANIZED WASHERS 75x75x8 PLACED ON BOTH ENDS OF ALL BOLTS.
 2. TOP BOLT CAN BE METAL STRAP.
 3. ALL DIMENSIONS ARE IN MILLIMETERS UNLESS OTHERWISE NOTED.

Selma Eskin

 Manager Structural Engineering

[Signature]

 Director Highway Engineering Services

[Signature]

 Executive Director Highway Engineering and Construction



No.	REVISION

Scale : N.T.S.
 Drawn by : WRP
 Checked by : R.SWINEMAR
 Date of Plan : 2007-05-29
 File No. : B-2007-144

**TIMBER BRIDGE BARRIER
 LVPL1**